

AM3156 – Filter Bank

Digitally Tunable 0.4 to 8 GHz Bandpass

Description

AM3156 is a fully integrated miniature digitally tunable bandpass filter bank covering the 0.4 to 8 GHz frequency range. The device exhibits 3 filter bands each with 256 discrete tune states and a low-loss filter bypass path contained in a 10mm QFN package. AM3156 expands on our AM3152 device by integrating the inductors and DC blocking capacitors and placing it all in one easy to install chip. AM3156 is an excellent front-end for a receiver providing both low insertion loss and valuable flexibility for tuning center frequency and bandwidth. Its small size, weight, and power consumption make it an attractive choice for demanding applications requiring low SWaP components.

Features

- Digitally Tunable Bandpass Filter
- Integrated Power and Control Line Filtering
- Integrated Inductors and DC Blocks
- 4.5 dB Insertion Loss
- 8 GHz Filter Bypass Path
- +3.3V to +5.0V Supply
- +3.3V to +5.0V Control
- 10mm QFN Package
- -40C to +85C Operation

Functional Diagram

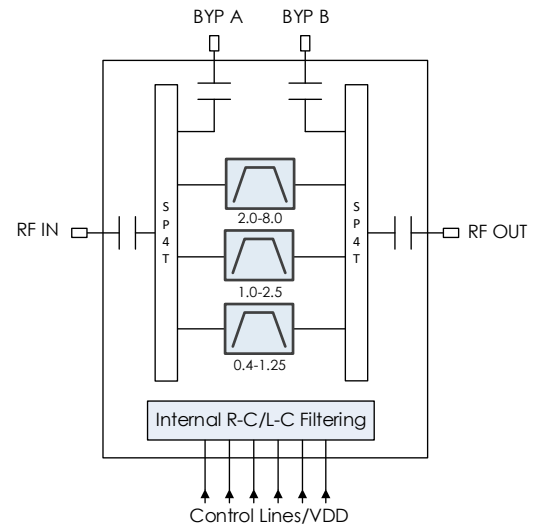

Characteristic Performance

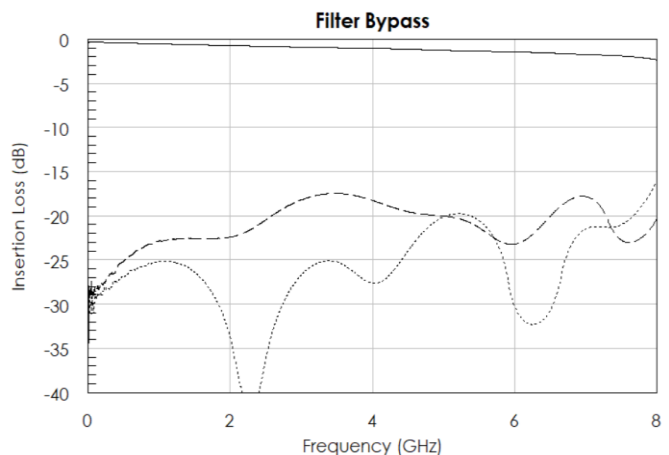
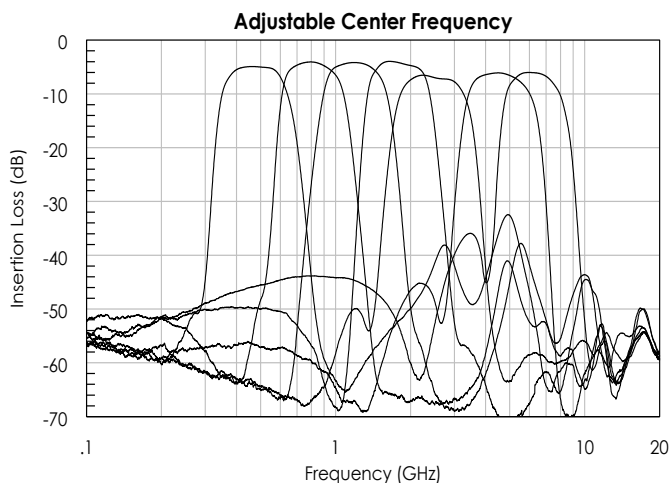

Table of Contents

Description	1	DC Electrical Characteristics	5
Features	1	RF Performance	5
Functional Diagram	1	State Table	5
Characteristic Performance	1	Timing Characteristics	5
Revision History	2	Typical Performance	7
Pin Layout and Definitions	3	Typical Application	9
Specifications	4	Evaluation PC Board	9
Absolute Maximum Ratings	4	Related Parts	10
Handling Information	4	Component Compliance Information	11
Recommended Operating Conditions	4		

Revision History

Date	Revision Number	Notes
June 11, 2021	1	Initial Release
September 3, 2021	1.1	Labels on Evaluation Board Corrected.
September 29, 2021	1.2	Incorrect Note on Pinout, Pin1 Fixed.

AM3156 – Filter Bank

Digitally Tunable 0.4 to 8 GHz Bandpass



Pin Layout and Definitions

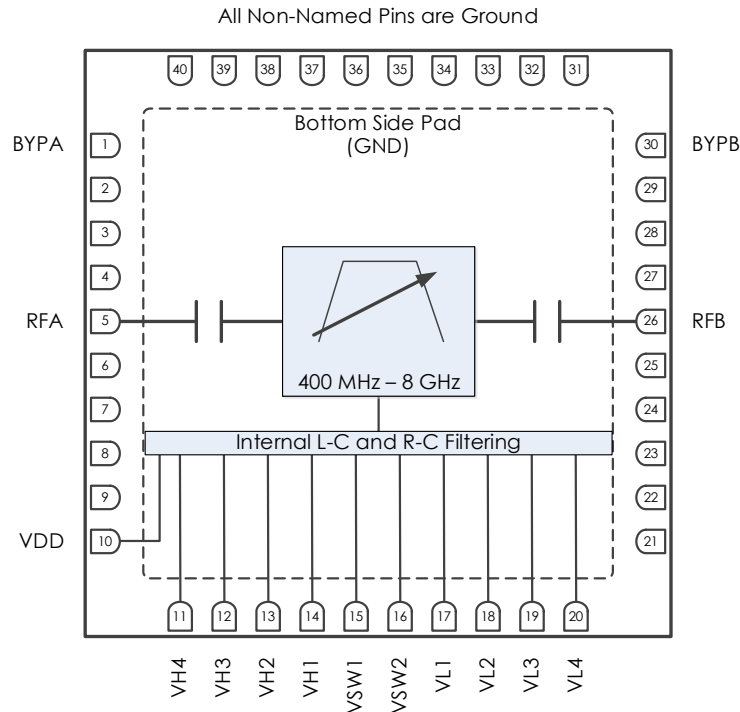

Pin Number	Pin Name	Pin Function
1	BYPA	Filter Bypass A – Return Pin 30 – 50 Ohms – AC Coupled*
2 – 4	GND	Ground – Common
5	RFA	RFA – 50 Ohms – AC Coupled. Can be Input or Output.
6 – 9	GND	Ground – Common
10	VDD	DC Power Input
11	VH4	Highpass Filter Control Bit 4 (MSB)
12	VH3	Highpass Filter Control Bit 3
13	VH2	Highpass Filter Control Bit 2
14	VH1	Highpass Filter Control Bit 1 (LSB)
15	VSW1	Switch Control 1
16	VSW2	Switch Control 2
17	VL1	Lowpass Filter Control Bit 1 (LSB)
18	VL2	Lowpass Filter Control Bit 2
19	VL3	Lowpass Filter Control Bit 3
20	VL4	Lowpass Filter Control Bit 4 (MSB)
21 – 25	GND	Ground – Common
26	RFB	RFB – 50 Ohms – AC Coupled. Can be Output or Input.
27 – 29	GND	Ground – Common
30	BYPB	Filter Bypass B – Return Pin 1 – 50 Ohms – AC Coupled. *
31 – 40	GND	Ground – Common
Bottom Pad	GND	Ground – Common

***Note:** Can be used for external filtering/switching or connected to return pin for a filter bypass path. Connecting BYPA directly to BYPB may reduce filter rejection > 8 GHz. To avoid this, you may place an external LPF filter between the two ports with cutoff frequency <= 8 GHz.

AM3156 – Filter Bank

Digitally Tunable 0.4 to 8 GHz Bandpass



Specifications

Absolute Maximum Ratings

	Minimum	Maximum
Supply Voltage	-0.3 V	+6.0 V
RF Input Power		+27 dBm
Operating Junction Temperature	-40 C	+150 C
Storage Temperature Range	-55 C	+150 C
Voltage at RF / Bypass Ports ¹		+16 WVDC

¹ Withstanding voltage of 40V for 5 seconds.

Note: Any device operation beyond the Absolute Maximum Ratings may result in permanent damage to the device. The values listed in this table are extremes and do not imply functional operation of the device at these or any other conditions beyond what is listed under Recommended Operating Conditions. Any part subjected to conditions outside of what is recommended for an extended amount of time may suffer from reliability concerns.

Handling Information

	Minimum	Maximum
Storage Temperature Range (Recommended)	-50 C	+125 C
Moisture Sensitivity Level	MSL 3	



Atlanta Micro products are electrostatic sensitive.
Follow safe handling practices to avoid damage

Recommended Operating Conditions

	Minimum	Typical	Maximum
Supply Voltage	+3.0 V*	+5.0 V	+5.2 V
Operating Case Temperature	-40 C		+85 C
Operating Junction Temperature	-40 C		+125 C

***Note:** Operating the AM3156 at VDD levels below +5.0V can cause corner frequencies to shift low by up to 2%. It is recommended to use +5.0V when possible. Control voltage level does not affect filter corner frequencies.

AM3156 – Filter Bank

Digitally Tunable 0.4 to 8 GHz Bandpass

DC Electrical Characteristics

(T = 25 °C unless otherwise specified)

Parameter	Testing Conditions	Minimum	Typical	Maximum
DC Supply Voltage		+3.0 V*	+5.0 V	+5.2 V
DC Supply Current	VDD = +5.0 V		10 mA	
Power Dissipated	VDD = +5.0 V		50 mW	
Logic Level Low		-0.1 V		0.5 V
Logic Level High		+2.0 V		+VDD
Logic Drive Level	VSWx/VHx/VLx = +5.0V	200 µA		

***Note:** Operating the AM3156 at VDD levels below +5.0V can cause corner frequencies to shift low by up to 2%. It is recommended to use +5.0V when possible. Control voltage level does not affect filter corner frequencies.

RF Performance

(T = 25 °C unless otherwise specified)

Parameter	Testing Conditions	Minimum	Typical	Maximum
Frequency Range	Tunable Filters	0.4 GHz		8 GHz
	Filter Bypass	1 MHz		8 GHz
Insertion Loss	Band 1		-4 dB	
	Band 2		-3.8 dB	
	Band 3		-6 dB	
Return Loss			-12 dB	
Input IP3			+40 dBm	

Timing Characteristics

Parameter	Minimum	Typical	Maximum
Band Switching Speed		130 ns	
Band 1 Tuning Speed		430 ns	
Band 2 Tuning Speed		420 ns	
Band 3 Tuning Speed		970 ns	

Note: Timing characteristics measured from 50% control to 90% RF.

State Table

SW2	SW1	Filter Band
Low	Low	Bypass State
Low	High	Band 1 – 0.4 to 1.25 GHz
High	Low	Band 2 – 1.0 to 2.5 GHz
High	High	Band 3 – 2.0 to 8.0 GHz

AM3156 – Filter Bank

Digitally Tunable 0.4 to 8 GHz Bandpass

State Table (continued)

High Pass Filter Typical Cutoff Frequencies (GHz)

VH4	VH3	VH2	VH1	Band 1	Band 2	Band 3
Low	Low	Low	Low	0.38	0.93	1.90
Low	Low	Low	High	0.39	0.95	1.93
Low	Low	High	Low	0.40	0.96	2.00
Low	Low	High	High	0.41	0.98	2.02
Low	High	Low	Low	0.42	1.00	2.11
Low	High	Low	High	0.43	1.02	2.16
Low	High	High	Low	0.45	1.05	2.25
Low	High	High	High	0.47	1.07	2.30
High	Low	Low	Low	0.50	1.17	2.70
High	Low	Low	High	0.52	1.20	2.80
High	Low	High	Low	0.55	1.23	2.95
High	Low	High	High	0.57	1.26	3.10
High	High	Low	Low	0.64	1.39	3.50
High	High	Low	High	0.68	1.43	3.75
High	High	High	Low	0.75	1.50	4.35
High	High	High	High	0.84	1.59	4.95

Low Pass Filter Typical Cutoff Frequencies (GHz)

VL4	VL3	VL2	VL1	Band 1	Band 2	Band 3
Low	Low	Low	Low	0.62	1.52	3.22
Low	Low	Low	High	0.64	1.55	3.27
Low	Low	High	Low	0.65	1.60	3.33
Low	Low	High	High	0.67	1.63	3.39
Low	High	Low	Low	0.69	1.69	3.55
Low	High	Low	High	0.71	1.73	3.60
Low	High	High	Low	0.73	1.79	3.70
Low	High	High	High	0.76	1.84	3.80
High	Low	Low	Low	0.78	1.92	4.10
High	Low	Low	High	0.81	1.97	4.25
High	Low	High	Low	0.85	2.05	4.50
High	Low	High	High	0.91	2.12	4.75
High	High	Low	Low	0.95	2.23	5.55
High	High	Low	High	1.04	2.32	6.00
High	High	High	Low	1.15	2.47	6.75
High	High	High	High	1.30	2.60	8.0

Note: State Table cutoff frequencies measured with VDD = 5.0V. Cutoffs are -3dB relative to Fc.

AM3156 – Filter Bank

Digitally Tunable 0.4 to 8 GHz Bandpass

Typical Performance

(VDD = +5.0V. Only some states shown for simplicity)

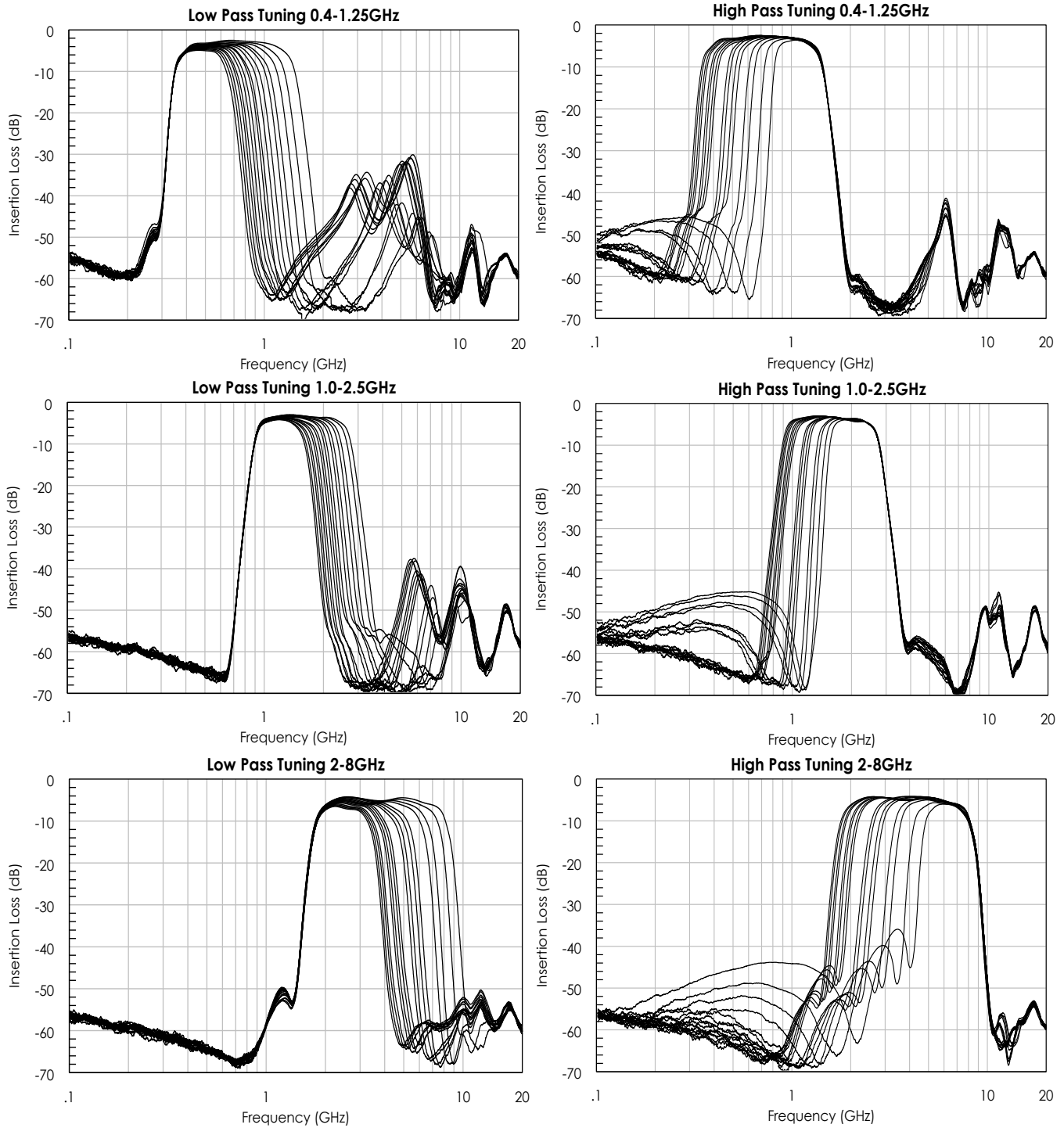

To obtain price, delivery, or to place an order contact sales@atlantamicro.com
 Atlanta Micro Inc., 3720 Davinci Ct, Suite 125, Peachtree Corners, GA 30092 • Phone: (470) 253-7640 • www.atlantamicro.com

AM3156 – Filter Bank

Digitally Tunable 0.4 to 8 GHz Bandpass

Typical Performance (continued)

(VDD = +5.0V. Only some states shown for simplicity)

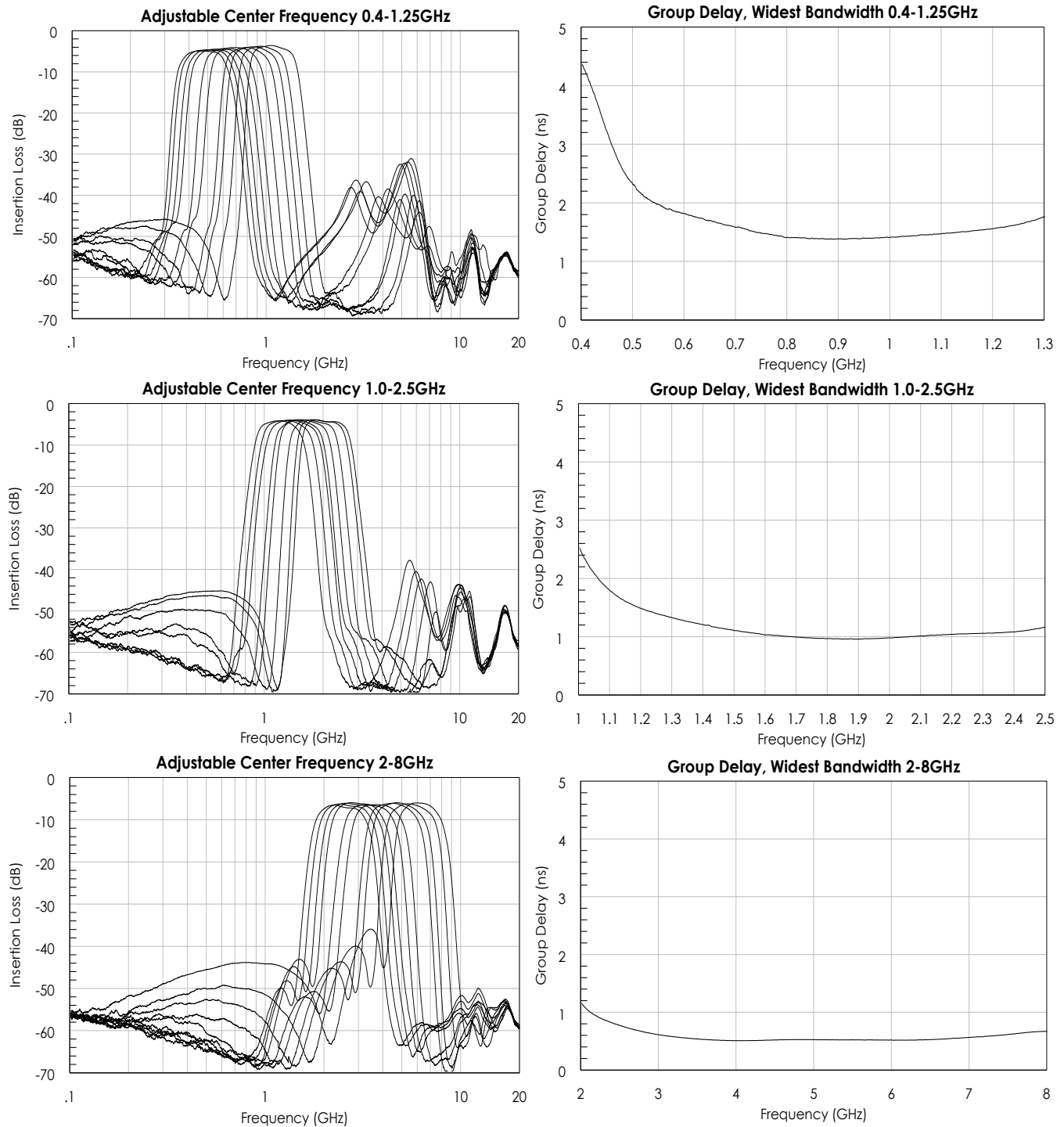

To obtain price, delivery, or to place an order contact sales@atlantamicro.com
 Atlanta Micro Inc., 3720 Davinci Ct, Suite 125, Peachtree Corners, GA 30092 • Phone: (470) 253-7640 • www.atlantamicro.com

Typical Application

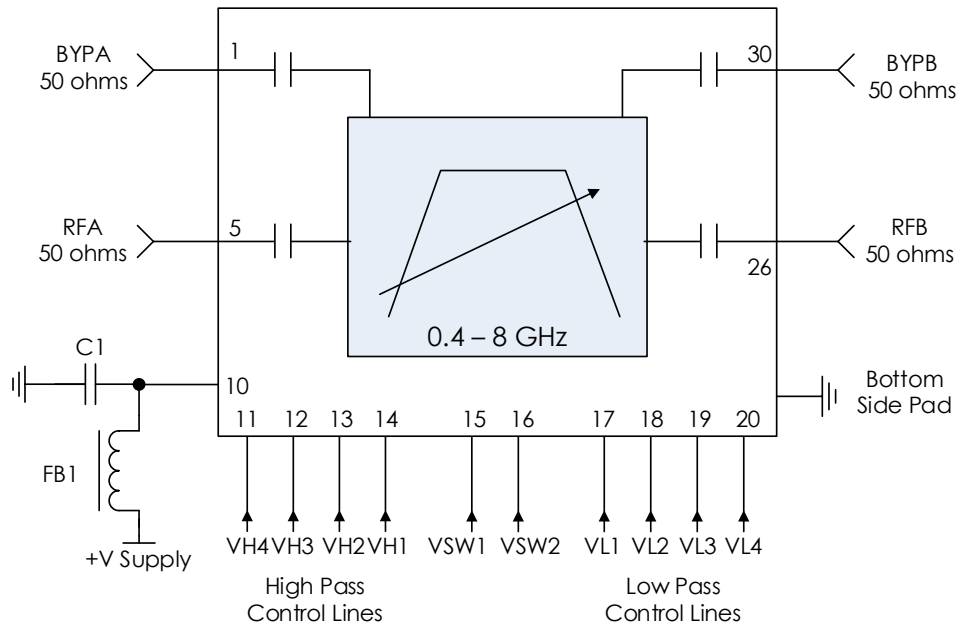

Recommended Component List (or equivalent):

Part	Value	Part Number	Manufacturer
C1	0.1 μ F	C1005X7R1H104K050BB	TDK
FB1	-	MMZ1005A222E	TDK

Notes:

- VDD and Control Lines filtered internally providing high frequency isolation.
 - It is recommended to add C1 and FB1 for further power line clean up.
 - No RC filtering required on pins 11 through 20. Switching and tuning speed reported in "Timing characteristics" section are inclusive of these internal filters.
- RFA, RFB, BYPA, and BYPB are AC coupled, no external DC blocking capacitors required.
- If top layer dielectric is < 6 mils then ground cutouts should be added under pins 1, 5, 26, and 30 to minimize parasitic capacitance. A cutout of 0.6mm x 1mm is recommended.

AM3156 – Filter Bank

Digitally Tunable 0.4 to 8 GHz Bandpass

Evaluation PC Board

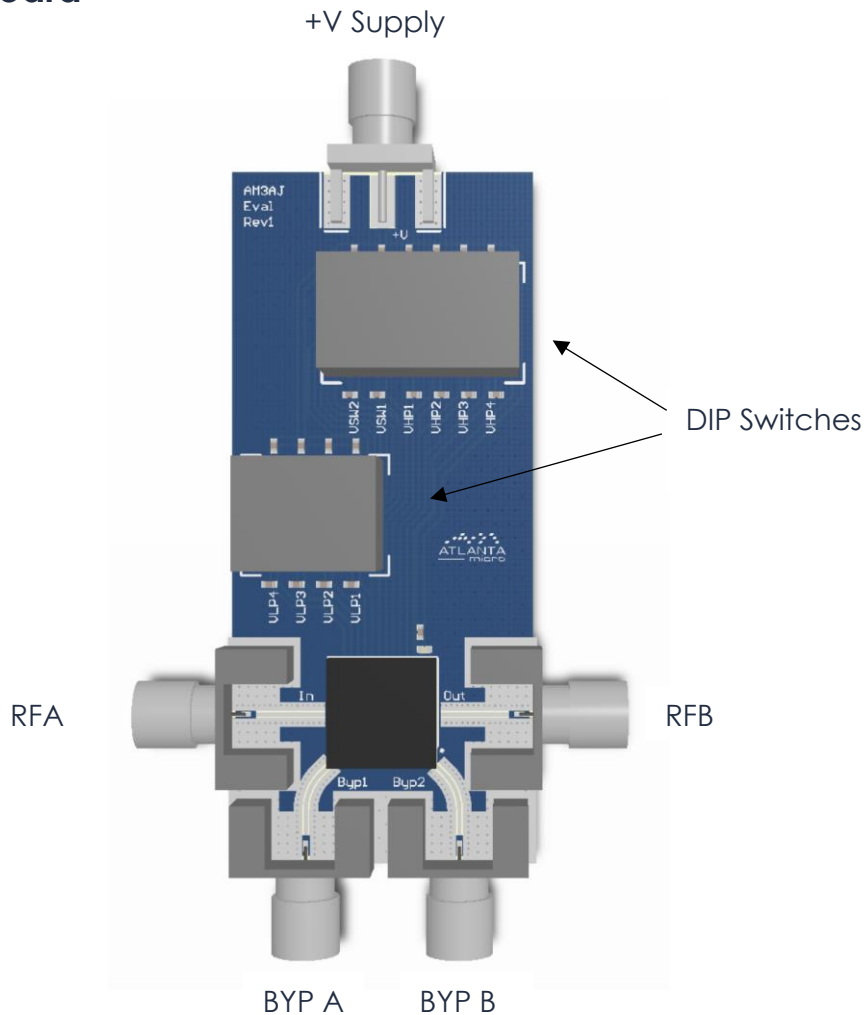

Related Parts

Part Number	Description		
AM3152	0.4 GHz	to	8 GHz Digitally Tunable Bandpass Filter
AM3090	100 MHz	to	450 MHz Digitally Tunable Bandpass Filter
AM3150	30 MHz	to	550 MHz Digitally Tunable Low Pass Filter
AM3151	20 MHz	to	360 MHz Digitally Tunable High Pass Filter

Component Compliance Information

RoHS: Atlanta Micro, Inc. hereby certifies that all products comply with the EC Directive 2011/65/EC on the Restriction of Hazardous Substances, commonly known as EU-RoHS 6 and 10. All products supplied by Atlanta Micro shall be compliant with the European Directive 2011/65/EC based on the following substance list.

Substance List	Allowable Maximum Concentration
Lead (Pb)	<1000 PPM (0.1% by weight)
Mercury (Hg)	<1000 PPM (0.1% by weight)
Cadmium (Cd)	<75 PPM (0.0075% by weight)
Hexavalent Chromium (CrVI)	<1000 PPM (0.1% by weight)
Polybrominated Biphenyls (PBB)	<1000 PPM (0.1% by weight)
Polybrominated Diphenyl ethers (PBDE)	<1000 PPM (0.1% by weight)
Decabromodiphenyl Deca BDE	<1000 PPM (0.1% by weight)
Bis (2-ethylhexyl) Phthalate (DEHP)	<1000 PPM (0.1% by weight)
Butyl Benzyl Phthalate (BBP)	<1000 PPM (0.1% by weight)
Dibutyl Phthalate (DBP)	<1000 PPM (0.1% by weight)
Diisobutyl Phthalate (DIBP)	<1000 PPM (0.1% by weight)

REACH: Atlanta Micro, Inc. neither uses nor intentionally adds any of the substances considered to be a Substance of Very High Concern (SVHC) as defined by the EU Regulation (EC) No. 1907-2006 on Registration, Evaluation, Authorization, and Restriction of Chemicals (REACH).

Conflict Materials: Atlanta Micro does not knowingly use materials that are sourced from the Democratic Republic of Congo (DRC) or any other known conflict regions. Atlanta Micro's supply chain is comprised of sources that are both environmentally and socially responsible. We periodically review this requirement with our vendors to ensure continued compliance.

Atlanta Micro takes its responsibility as a global partner seriously and will use due diligence within our supply chain to ensure all standards are met to the best of our knowledge.