

AM3089 Application Note

Analog Tunable 2.0 to 18.0 GHz Bandpass

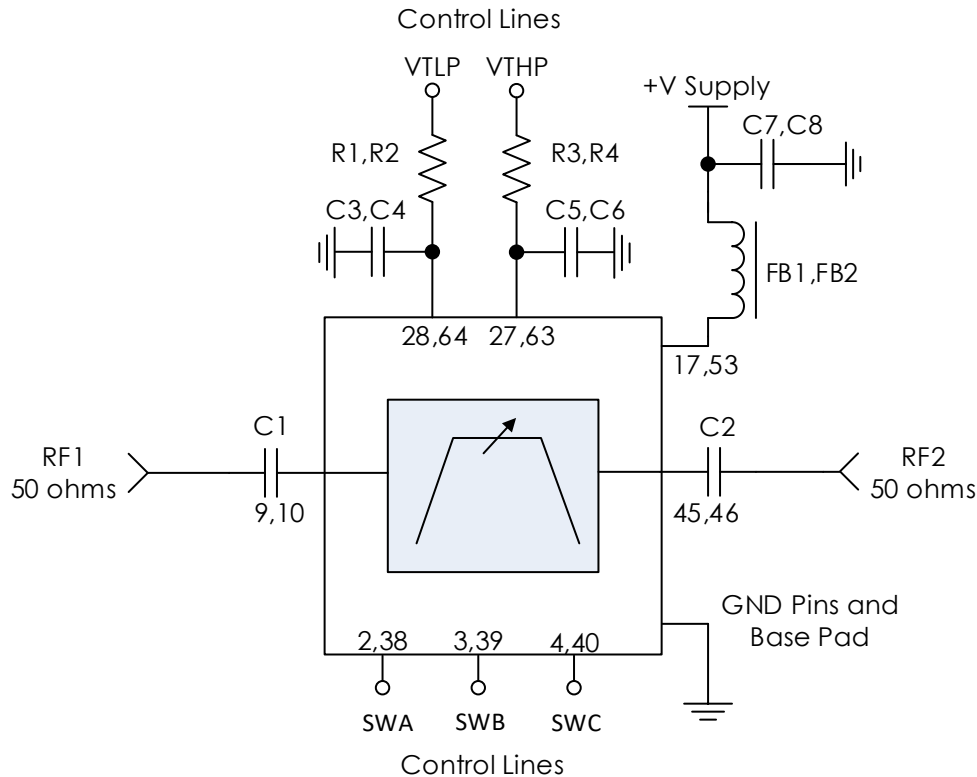

Typical Application



Recommended Component List (or equivalent):

Part	Value	Part Number	Manufacturer
C1,C2	0.1 μ F	0402BB104KW160	Passives Plus
C3-C8	0.1 μ F	C1005X7R1H104K050BB	TDK
FB1,FB2		MMZ1005A222E	TDK
R1 – R4	100 Ω	CRCW0402100RFKED	Vishay

Notes:

1. RC filtering on the control lines is recommended to prevent digital noise from coupling to the RF path. Select control line RC filter values based on desired logic source decoupling and switching speed.

Recommended Layout

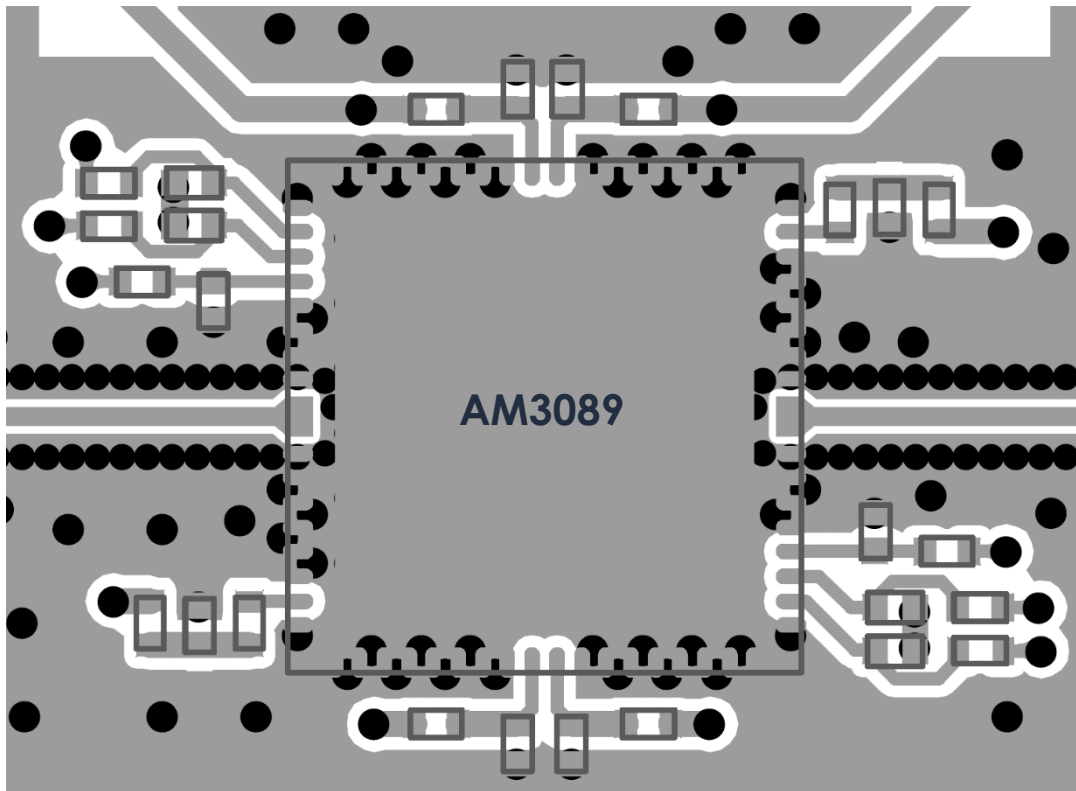

Notes:

1. Power line filtering is made symmetric here such that it is L – C – L filtering. L – C filtering may be used if space is critical.
2. Recommended input trace is grounded coplanar waveguide, 50 ohms.
3. IC and RF inputs / outputs should be via fenced.
4. Vias should be placed under IC and GND pads (not shown).
5. Vias shown are 10mil hole size with 24mil pad.
6. DC blocks not shown here, though still required.

Revision History

Date	Revision Number	Notes
April 10, 2020	1	Initial Release