

# AM3060 Application Note

## Digitally Tunable Bandpass 0.32 – 6.5 GHz

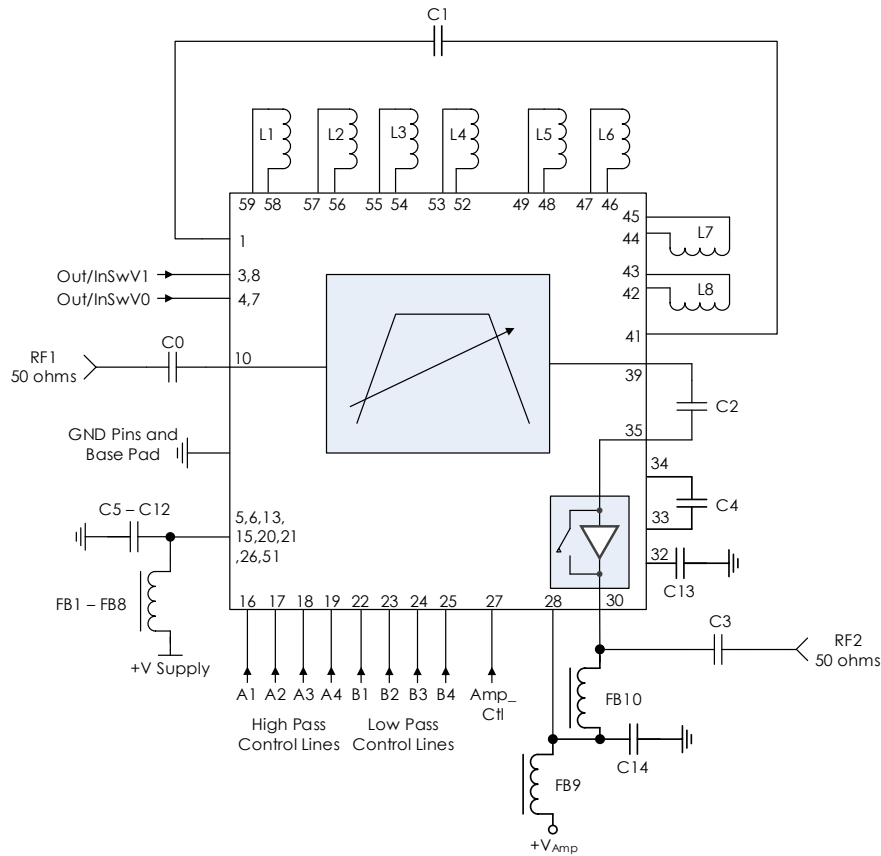

### Typical Application



### Recommended Component List (or equivalent):

Part	Value	Part Number	Manufacturer
C0 – C4	0.1 $\mu$ F	0201BB104KW160	Passives Plus
C5-C14	0.1 $\mu$ F	C1005X7R1H104K050BB	TDK
FB1-10	-	MMZ1005A222E	TDK
L1, L4	13 nH	0402HP-13NXGLW	Coilcraft
L2, L3	9.0 nH	0402HP-9N0XGLW	Coilcraft
L5, L8	5.6 nH	0402HP-5N6XGLW	Coilcraft
L6, L7	6.2 nH	0402HP-6N2XGLW	Coilcraft

### Notes:

1. RC filtering on the control lines is recommended to prevent digital noise from coupling to the RF path
2. Select control line RC filter values based on desired logic source decoupling and switching speed
3. Out/InSwV0/1 may be tied together but should be filtered independently.

### Recommended Layout

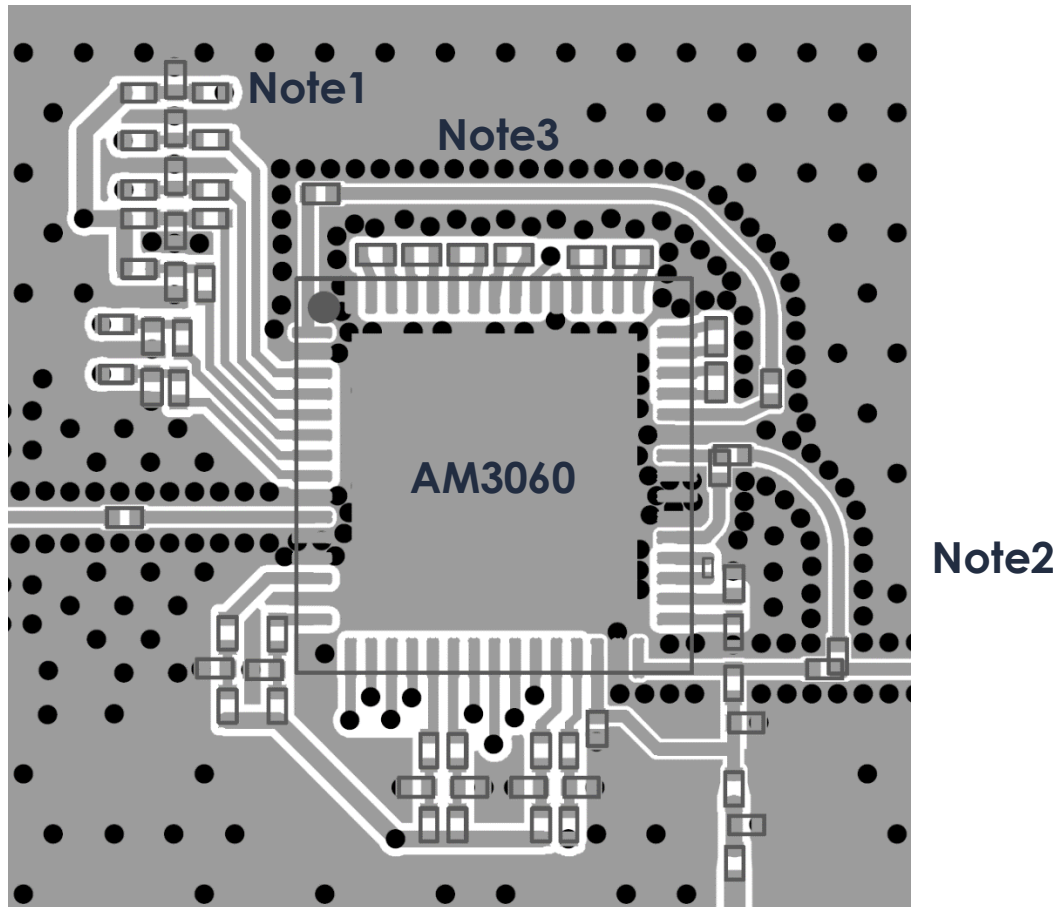

#### Notes:

1. VDD goes back into board under bypass path
2. Shown here is a user switchable capacitor to switch between using the included amplifier or not. These extra components are not required if only using one mode of operation and is shown here for example only.
3. External inductors should be as close as possible to the AM3060. Placing inductors orthogonal is not required and should prefer being close to the IC.
4. Power line filtering is made symmetric here such that it is L – C – L filtering. L – C filtering may be used if space is critical.
5. Recommended input trace is grounded coplanar waveguide, 50 ohms.
6. IC and RF inputs / outputs should be via fenced.
7. Vias should be placed under IC and GND pads (not shown).
8. Vias shown are 10mil hole size with 24mil pad.

# AM3060 Application Note

---

## Digitally Tunable Bandpass 0.32 – 6.5 GHz



### Revision History

Date	Revision Number	Notes
April 10, 2020	1	Initial Release