

AM9018 – Receiver Mini-Module Overview

0.9 GHz to 18 GHz Wideband Miniature Tuner Module

Description

AM9018 is a fully integrated tuner module that provides high dynamic range coverage from 0.9 GHz to 18 GHz. The tuner also provides a bypass path from 10 MHz to 6 GHz for direct spectrum capture. The heterodyne tuner module is designed for high performance and low size, weight, and power (low SWaP) and is mechanically mountable to a host circuit board for use in multi-channel receiver applications.



Input limiter, sub-octave preselectors, pre-amplifiers, local oscillators, frequency converters, ADC driver amplifiers, power and control line filtering, a temperature sensor, and a control FPGA are included as well as a calibration input port. The analog IF output frequency is centered at 2 GHz with a 1 GHz bandwidth. Multiple tuner sets can be configured to work together for coherent operation and N-channel applications. Interfacing to the tuner is accomplished by simply providing an RF input, DC voltages, frequency reference, SPI control, and routing the IF output.

Features

- 0.9 GHz to 18 GHz Frequency Range
- 1 GHz Bandwidth
- 2 GHz IF Output Frequency
- 10 MHz to 6 GHz Tuner Bypass Path
- Optional 500 MHz bandwidth with 1GHz IF (Operating Range 0.4 GHz to 18 GHz)
- Input Signal Limiter
- Calibration Input Port
- Sub-Octave Preselection
- Integrated Temperature Sensor
- 14 dB Noise Figure, +5 dBm IIP3
- +5.0V and +3.3V DC Operation
- 6.0 W Max Power Consumption
- -40C to +85C Operation
- 1.6oz / 45g Module Weight
- 1.40" x 3.00" x 0.270" (35.6 x 76.2 x 6.8 mm)

Part Ordering Details

Part Number	Description
AM9018-1	Stand-alone Tuner Module, 2.0 GHz IF Output w/ 1 GHz Bandwidth
AM9018-2	Stand-alone Tuner Module, 1.0 GHz IF Output w/ 500 MHz Bandwidth
AM9018-xEVAL*	Single Channel AM9018-1 Evaluation Board
AM9018-xEVAL-2CH*	Dual Channel AM9018-1 Evaluation Board
AM9018-xEVAL-4CH*	Quad Channel AM9018-1 Evaluation Board

* Substitute 1 or 2 for x for the version of AM9018 to be installed.

Note: Eval boards include low-dropout regulators, reference distribution circuitry, and control circuitry. All that is required for operation is an input signal, a reference, and a Windows computer for the USB control of the evaluation board. The output may be driven into a spectrum analyzer or directly into an ADC. Contact Atlanta Micro for ADC recommendations

AM9018 – Receiver Mini-Module Overview

0.9 GHz to 18 GHz Wideband Miniature Tuner Module

Revision History

Date	Revision Number	Notes
August 11, 2020	1	Preliminary Release
November 6, 2020	2	Update block diagram and dimensions
January 8, 2021	3	Updated module size
January 15, 2021	4	Pinout for multipin
September 10, 2021	5	Initial Release
April 1, 2022	6.1	Updated part ordering details. Added weight.

Specifications

Absolute Maximum Ratings

	Testing Condition	Minimum	Maximum
RF Input Power	Pulsed		9.0 W
	Continuous Wave		2.0 W
+5.0 VDC Supply			+5.5 V
+3.3 VDC Supply			+3.6 V
Operating Temperature		-40 C	+85 C
Storage Temperature Range		-55 C	+150 C

Note: Any device operation beyond the Absolute Maximum Ratings may result in permanent damage to the device. The values listed in this table are extremes and do not imply functional operation of the device at these or any other conditions beyond what is listed under Recommended Operating Conditions. Any part subjected to conditions outside of what is recommended for an extended amount of time may suffer from reliability concerns.

Handling Information

	Minimum	Maximum
Storage Temperature Range (Recommended)	-50 C	+125 C



Atlanta Micro products are electrostatic sensitive.
Follow safe handling practices to avoid damage

Recommended Operating Conditions

	Minimum	Typical	Maximum
Operating Case Temperature	-40 C		+85 C

AM9018 – Receiver Mini-Module Overview

0.9 GHz to 18 GHz Wideband Miniature Tuner Module

DC Electrical Characteristics

(T = 25 °C unless otherwise specified)

Parameter	Testing Conditions	Minimum	Typical	Maximum
+5 VDC Supply		+4.8 V	+5.0 V	+5.2 V
+3.3 VDC Supply		+3.2 V	+3.3 V	+3.5 V
+5 VDC Current				0.5 A
+3.3 VDC Current				1.1 A
Power Dissipated				6.1 W
Logic Level Low		0 V		+0.8 V
Logic Level High		+2.0 V		+3.5 V

RF Performance

(T = 25 °C unless otherwise specified)

Parameter	Notes	Minimum	Typical	Maximum
Frequency Range	Heterodyne Path	0.9 GHz		18 GHz
	Bypass Path	10 MHz		6 GHz
Instantaneous Bandwidth			1.0 GHz	
IF Center Frequency			2.0 GHz	
Tune Frequency Range		1.4 GHz		17.5 GHz
Tuning Step Size			5 MHz	
Frequency Reference	External Reference Required		100 MHz, 0 dBm	
Input Limiter P1dB			+14 dBm	
Input Limiter Recovery Time			10 ps	
Input IP3			+5 dBm	
Input IP2			+60 dBm	
Noise Figure			14 dB	
Image Rejection		70 dB		
IF Rejection	Stopband Relative to Passband	70 dB	80 dB	
LO Radiation	Measured at Antenna In		-80 dBm	
LO Leakage	Measured at IF Output		-70 dBm	
Gain			24 dB +/-2dB	
Gain Control ¹			45 dB	
Tuning Speed			100 μ s	450 μ s ²
Phase Noise	1 kHz Offset		-90 dBc/Hz	
	10 kHz Offset		-100 dBc/Hz	
	100 kHz Offset		-100 dBc/Hz	
	1 MHz Offset		-106 dBc/Hz	
	10 MHz Offset		-127 dBc/Hz	

Note 1: Additional gain control beyond calibrated gain, in 1 dB steps. Heterodyne path only.

Note 2: Longest tune speed is seen when switching from $F_c \leq 5500$ to $F_c > 5500$ or from $F_c > 5500$ to $F_c \leq 5500$. Switching between center frequencies in either $F_c \leq 5500$ range or $F_c > 5500$ range will follow typical tuning speed.

AM9018 – Receiver Mini-Module Overview

0.9 GHz to 18 GHz Wideband Miniature Tuner Module

Mechanical Details

Mechanical Drawing

Bottom View

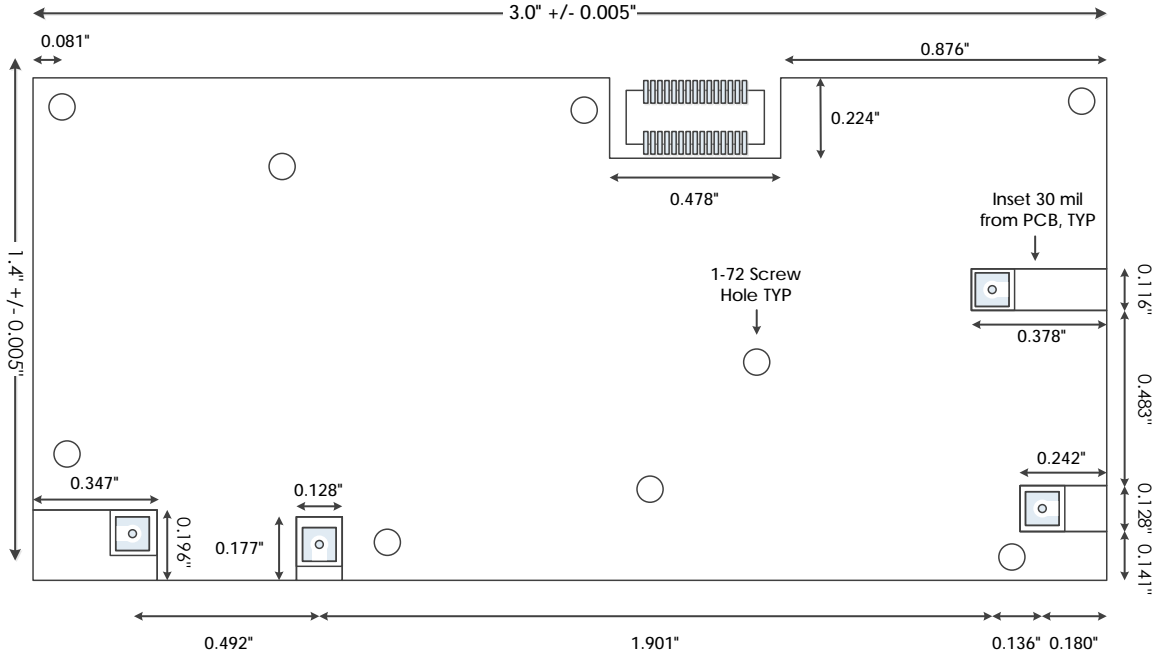

Side View

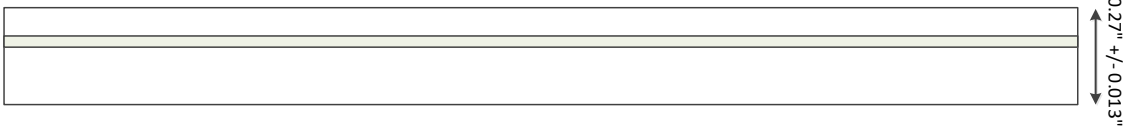

Top View



AM9018 – Receiver Mini-Module Overview

0.9 GHz to 18 GHz Wideband Miniature Tuner Module

Evaluation PC Board

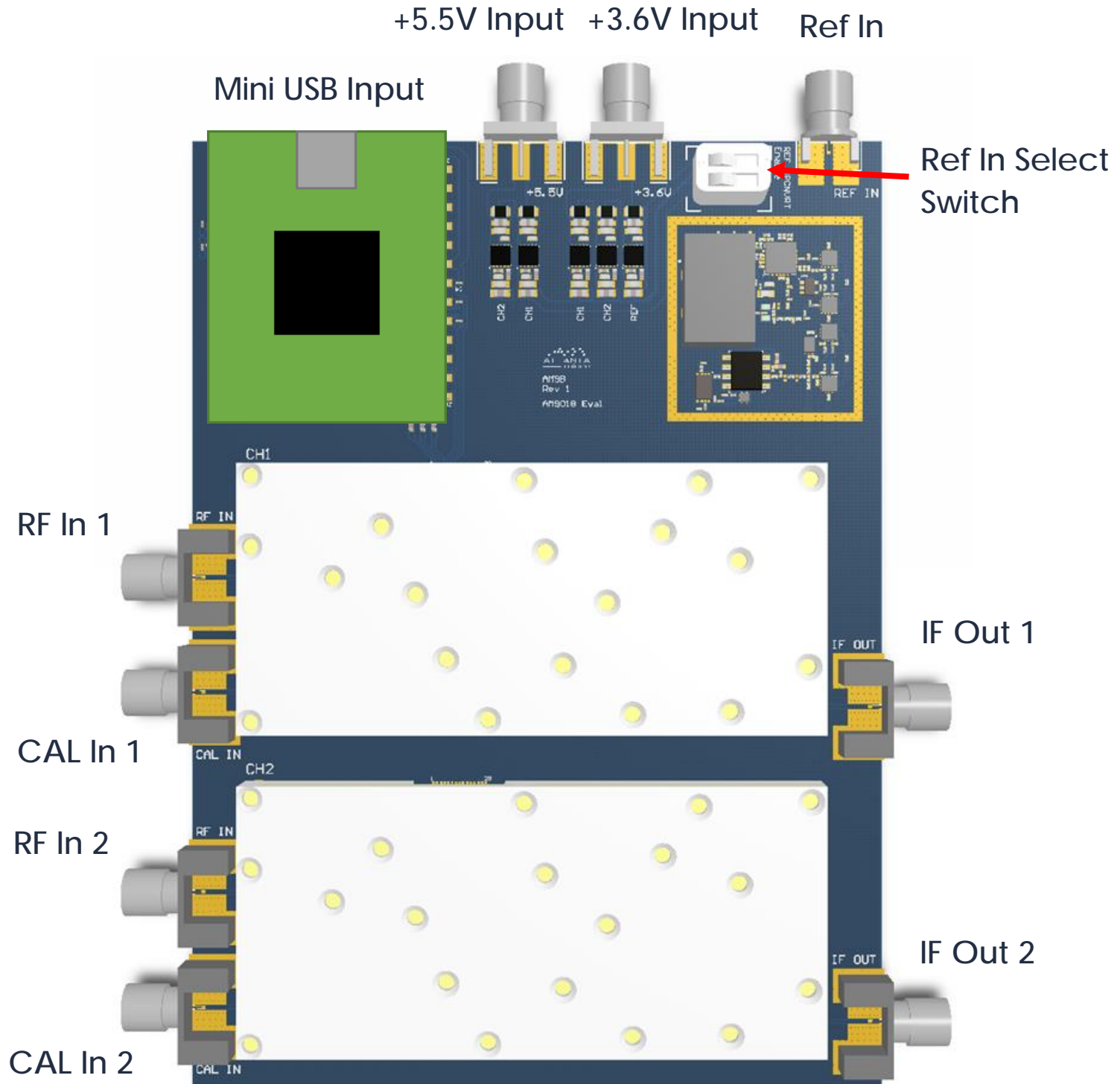

*Note 1: Evaluation board supports up to two tuners to test phase coherent operation if desired.