

1.3mm x 2mm FB Amplifier Application Note

VDD on RF Out

Typical Application

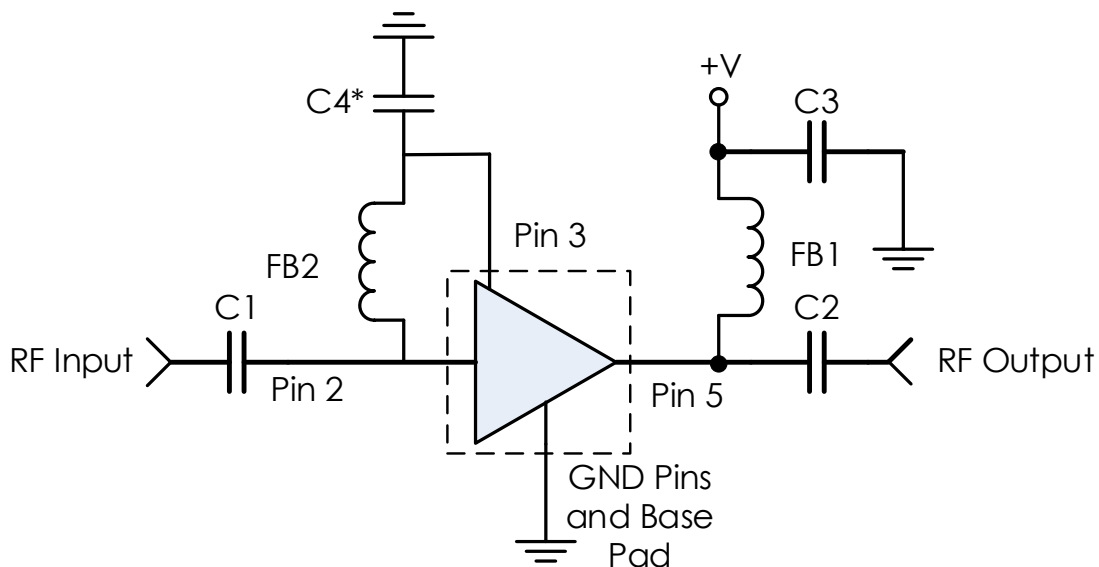

Recommended Component List (or equivalent):

Part	Value	Part Number	Manufacturer
C1, C2	0.1 μ F	0201BB104KW160	Passives Plus
C3, C4	0.1 μ F	GRM155R71C104KA88	Murata
FB1, FB2	-	MMZ1005A222E	TDK

Notes

1. Application shown above is the minimum needed for an operational circuit. The circuit above is representative of the s-parameters as available on the website.
2. Install C4 for best noise figure below 50 MHz. If operating above 50 MHz, C4 is not needed.
3. To choose the best component for FB2, Atlanta Micro recommends the following:
 - a. First, determine your desired frequency range of operation.
 - b. Next, design your output bias tee (FB1/C3 + any other components) for your desired power supply isolation and chosen frequency range.
 - c. The component(s) used for FB2 should then be component(s) as used in your bias tee that connect to the main RF output (pin 5) line only.
 - i. This does not need to be the whole bias tee design.
 - ii. This should be all components before the first decoupling capacitor on the bias tee.
 - iii. In the example above, FB2 = FB1.

1.3mm x 2mm FB Amplifier Application Note

VDD on RF Out

Recommended Layout

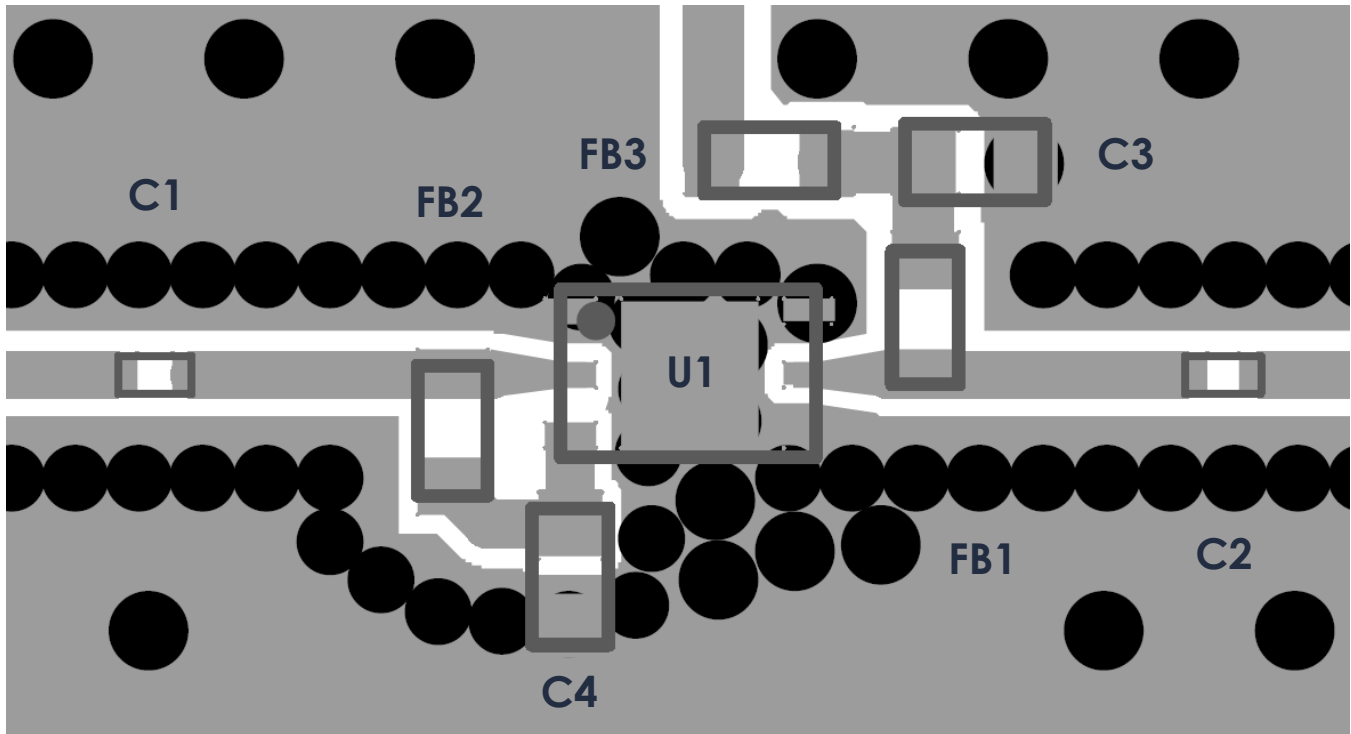

Notes:

1. FB3 = FB1 = MMZ1005A222E for symmetry.
2. C4 = C3 = GRM155R71C104KA88. C4 recommended for better noise figure performance below 50 MHz. If operating above 50 MHz C4 is not needed.
3. Recommended input trace is grounded coplanar waveguide, 50 ohms.
4. IC and RF input / output should be via fenced.
5. Vias should be placed under IC and GND pads.
6. Components recommended and shown above are 0402 components though 0201 component may also be used.

Revision History

Date	Revision Number	Notes
June 25, 2020	1	Initial Release
August 31, 2020	2	Additional Notes Added to Typical Application
February 15, 2021	3	Additional Notes for FB2 selection added. Added Information for capacitor at pin 5 input.