

AM3066 – Filter Bank

Digitally Tunable 12 to 26.5 GHz Bandpass

Description

AM3066 is a miniature filter IC containing digitally tunable bandpass filters covering the 12.0 GHz to 26.5 GHz frequency range. Separate low-pass and high-pass control lines provide independent control of both center frequency and bandwidth. Power and Control lines are internally filtered using Atlanta Micro's AM35 filter chip. AM3066 provides an excellent filtering solution for a receiver or transceiver requiring flexible center frequency and bandwidth, high dynamic range, and small size, weight, and power consumption.



Features

- Digitally Tunable Bandpass Filters
- Independent LP and HP control
- +3.3V to +5.0V Supply
- 5.0 dB Insertion Loss
- Integrated Power and Control Line Filtering (See AM35 Datasheet)
- 6mm QFN Package
- +40 dBm Input IP3
- -40C to +85C Operation

Functional Diagram

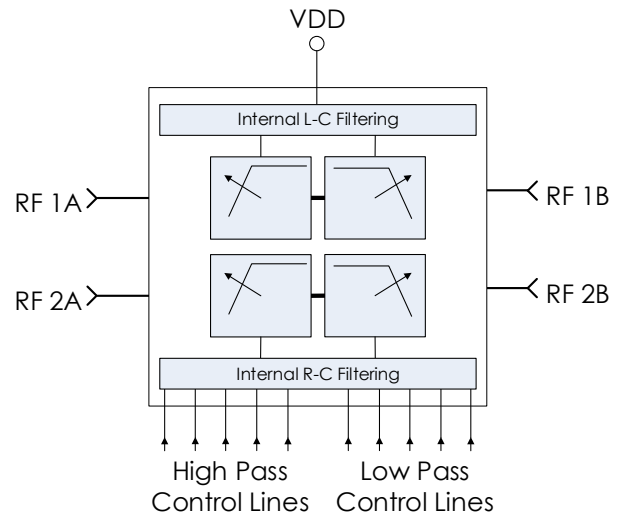

Characteristic Performance

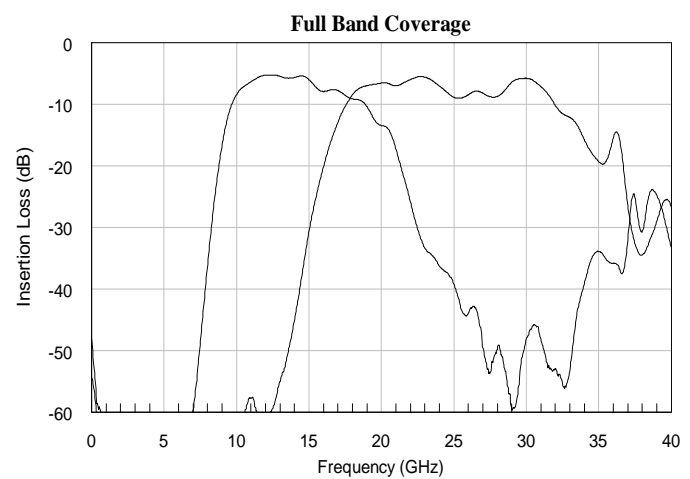
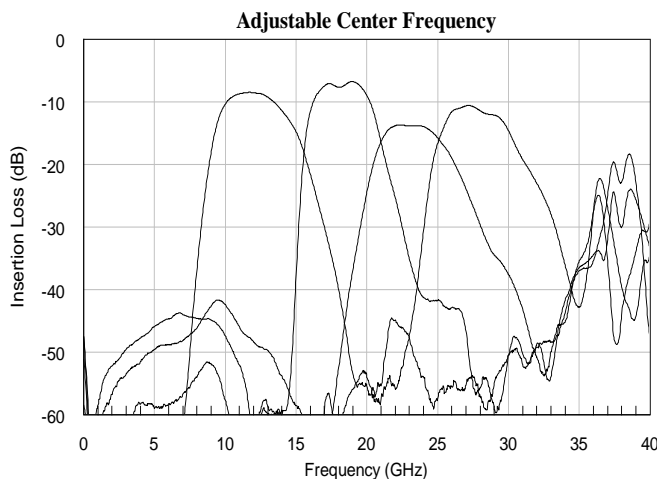

Table of Contents

Description	1	RF Performance.....	6
Features	1	Timing Characteristics	6
Functional Diagram	1	State Tables.....	7
Characteristic Performance	1	Typical Performance	11
Revision History	2	Typical Application	13
Pin Layout and Definitions	3	Package Details	14
Specifications	5	Evaluation PC Board	15
Absolute Maximum Ratings.....	5	Related Parts	15
Handling Information.....	5	Component Compliance Information ...Error!	
Recommended Operating Conditions ...	5	Bookmark not defined.	
DC Electrical Characteristics.....	6		

Revision History

Date	Revision Number	Notes
March 30, 2018	1	Preliminary Release
May 9, 2018	2	Updated for new datasheet format
August 17, 2018	3	Specifications Updated
August 22, 2018	3A	Various Pictures Updated
July 17, 2019	4	Various Notes Added, Component Footprint Updated, Various Performance Details Added.

AM3066 – Filter Bank

Digitally Tunable 12 to 26.5 GHz Bandpass



Pin Layout and Definitions

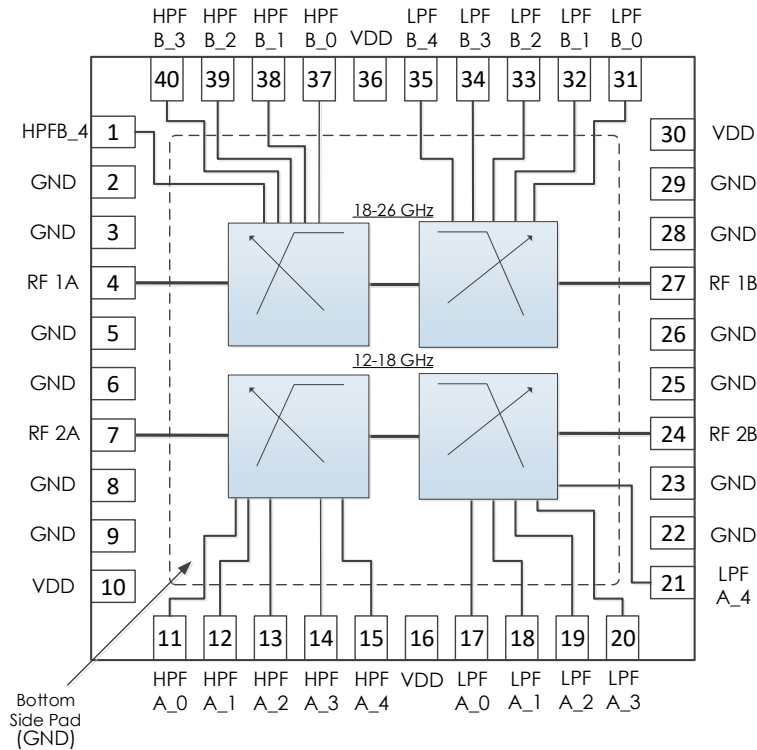

Pin Number	Pin Name	Pin Function
1	HPFB_4	18-26 GHz HPF control bit 4
2,3	GND	Ground – Common
4	RF1A	18-26 GHz RF Port 1 – 50 ohms – DC coupled – DC blocking capacitor required*
5,6	GND	Ground – Common
7	RF2A	12-18 GHz RF Port 1 – 50 ohms – DC coupled – DC blocking capacitor required*
8,9	GND	Ground – Common
10	VDD	DC Supply
11	HPFA_0	12-18 GHz HPF control bit 0
12	HPFA_1	12-18 GHz HPF control bit 1
13	HPFA_2	12-18 GHz HPF control bit 2
14	HPFA_3	12-18 GHz HPF control bit 3
15	HPFA_4	12-18 GHz HPF control bit 4
16	VDD	DC Supply
17	LPFA_0	12-18 GHz LPF control bit 0
18	LPFA_1	12-18 GHz LPF control bit 1
19	LPFA_2	12-18 GHz LPF control bit 2
20	LPFA_3	12-18 GHz LPF control bit 3
21	LPFA_4	12-18 GHz LPF control bit 4

***Note:** DC blocking caps not required if in series with other Atlanta Micro parts of the same reference voltage.

AM3066 – Filter Bank

Digitally Tunable 12 to 26.5 GHz Bandpass

Pin Layout and Definitions (continued)

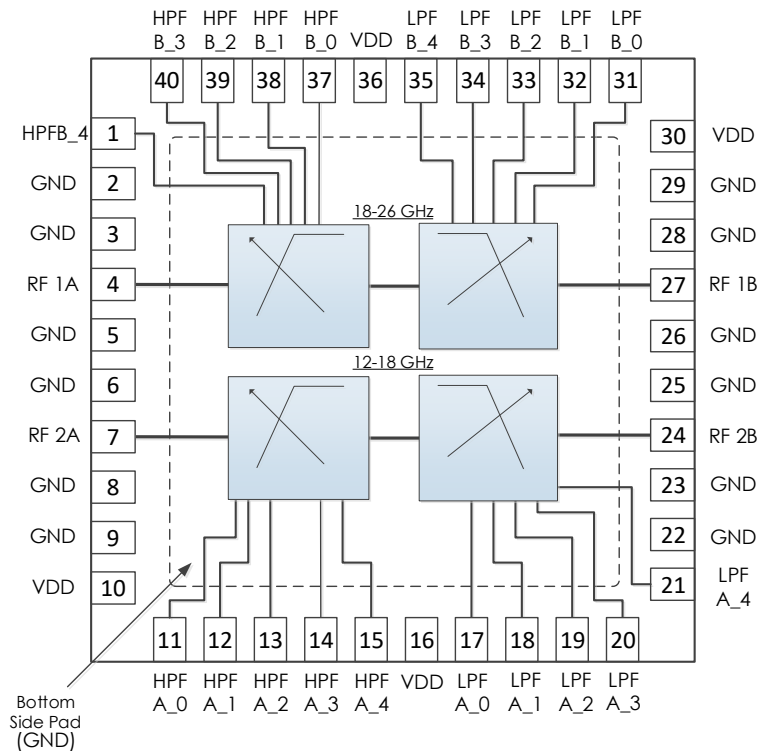

Pin Number	Pin Name	Pin Function
22,23	GND	Ground – Common
24	RF2B	12-18 GHz RF Port 2 – 50 ohms – DC coupled – DC blocking capacitor required*
25,26	GND	Ground – Common
27	RF1B	18-26 GHz RF Port 2 – 50 ohms – DC coupled – DC blocking capacitor required*
28,29	GND	Ground - Common
30	VDD	DC Supply
31	LPFB_0	18-26 GHz LPF control bit 0 (reserved for future use)
32	LPFB_1	18-26 GHz LPF control bit 1
33	LPFB_2	18-26 GHz LPF control bit 2
34	LPFB_3	18-26 GHz LPF control bit 3
35	LPFB_4	18-26 GHz LPF control bit 4
36	VDD	DC Supply
37	HPFB_0	18-26 GHz HPF control bit 0
38	HPFB_1	18-26 GHz HPF control bit 1
39	HPFB_2	18-26 GHz HPF control bit 2
40	HPFB_3	18-26 GHz HPF control bit 3
Case GND	GND	Ground - Common

***Note:** DC blocking caps not required if in series with other Atlanta Micro parts of the same reference voltage.

AM3066 – Filter Bank

Digitally Tunable 12 to 26.5 GHz Bandpass



Specifications

Absolute Maximum Ratings

	Minimum	Maximum
Supply Input Voltage	-0.3 V	+6.0 V
RF Input Power		+27dBm
Operating Junction Temperature	-40 C	+150 C
Storage Temperature Range	-50C	+150 C

Handling Information

	Minimum	Maximum
Storage Temperature Range (Recommended)	-50 C	+125 C
Moisture Sensitivity Level	MSL 3	



Atlanta Micro products are electrostatic sensitive.
Follow safe handling practices to avoid damage

Recommended Operating Conditions

	Minimum	Typical	Maximum
Supply Voltage	+2.7 V	+5.0 V	
Operating Case Temperature	-40 C		+85 C
Operating Junction Temperature	-40 C		+125 C

AM3066 – Filter Bank

Digitally Tunable 12 to 26.5 GHz Bandpass

DC Electrical Characteristics

Parameter	Testing Conditions	Minimum	Typical	Maximum
DC Supply Voltage		+2.7 V	+5.0 V	
DC Supply Current	VDD = +5.0V		2mA	
Power Dissipated	VDD = +5.0V		10mW	
Logic Level Low		-0.1V		+0.5V
Logic Level High		+2.0V		+VDD

*Power and Control lines are internally filtered. See AM35 datasheet for performance details.

RF Performance

Parameter	Testing Conditions	Minimum	Typical	Maximum
Frequency Range		12.0 GHz		26.0 GHz
Insertion Loss	f = 12.0 GHz		5.3 dB	
	f = 18.0 GHz		7.5 dB	
	f = 26.5 GHz		7.8 dB	
Return Loss	f = 12.0 GHz		17.0 dB	
	f = 18.0 GHz		15.9 dB	
	f = 26.5 GHz		10.8 dB	
Input IP3			+40 dBm	

Timing Characteristics

Parameter	Minimum	Typical	Maximum
Switching Speed		1 μ s	

AM3066 – Filter Bank

Digitally Tunable 12 to 26.5 GHz Bandpass



State Tables

12 – 18 GHz High Pass Control Lines					Typical Cutoff Frequency (GHz)
A_4	A_3	A_2	A_1	A_0	
L	L	L	L	L	10.23
L	L	L	L	H	10.31
L	L	L	H	L	10.37
L	L	L	H	H	10.46
L	L	H	L	L	10.56
L	L	H	L	H	10.65
L	L	H	H	L	10.73
L	L	H	H	H	10.87
L	H	L	L	L	10.98
L	H	L	L	H	11.07
L	H	L	H	L	11.18
L	H	L	H	H	11.37
L	H	H	L	L	11.50
L	H	H	L	H	11.62
L	H	H	H	L	11.37
L	H	H	H	H	11.74
H	L	L	L	L	11.80
H	L	L	L	H	11.85
H	L	L	H	L	11.98
H	L	L	H	H	12.22
H	L	H	L	L	12.42
H	L	H	L	H	12.73
H	L	H	H	L	13.06
H	L	H	H	H	13.26
H	H	L	L	L	13.80
H	H	L	L	H	14.02
H	H	L	H	L	14.27
H	H	L	H	H	15.11
H	H	H	L	L	15.50
H	H	H	L	H	16.10
H	H	H	H	L	16.43
H	H	H	H	H	16.89

AM3066 – Filter Bank

Digitally Tunable 12 to 26.5 GHz Bandpass



State Tables (continued)

12 – 18 GHz Low Pass Control Lines					Typical Cutoff Frequency (GHz)
A_4	A_3	A_2	A_1	A_0	
L	L	L	L	L	9.00
L	L	L	L	H	9.20
L	L	L	H	L	9.28
L	L	L	H	H	9.29
L	L	H	L	L	9.49
L	L	H	L	H	9.62
L	L	H	H	L	9.73
L	L	H	H	H	9.83
L	H	L	L	L	10.05
L	H	L	L	H	10.23
L	H	L	H	L	10.31
L	H	L	H	H	10.47
L	H	H	L	L	10.61
L	H	H	L	H	10.87
L	H	H	H	L	11.00
L	H	H	H	H	11.19
H	L	L	L	L	11.25
H	L	L	L	H	11.49
H	L	L	H	L	11.69
H	L	L	H	H	11.94
H	L	H	L	L	12.18
H	L	H	L	H	12.40
H	L	H	H	L	12.68
H	L	H	H	H	12.84
H	H	L	L	L	13.35
H	H	L	L	H	14.08
H	H	L	H	L	14.86
H	H	L	H	H	15.73
H	H	H	L	L	16.50
H	H	H	L	H	17.85
H	H	H	H	L	18.54
H	H	H	H	H	19.80

AM3066 – Filter Bank

Digitally Tunable 12 to 26.5 GHz Bandpass



State Tables (continued)

18 – 26.5 GHz High Pass Control Lines					Typical Cutoff Frequency (GHz)
B_4	B_3	B_2	B_1	B_0	
L	L	L	L	L	17.91
L	L	L	L	H	18.02
L	L	L	H	L	18.16
L	L	L	H	H	18.36
L	L	H	L	L	18.50
L	L	H	L	H	18.79
L	L	H	H	L	18.99
L	L	H	H	H	19.25
L	H	L	L	L	19.42
L	H	L	L	H	19.60
L	H	L	H	L	19.74
L	H	L	H	H	20.01
L	H	H	L	L	20.45
L	H	H	L	H	20.68
L	H	H	H	L	20.93
L	H	H	H	H	21.22
H	L	L	L	L	21.38
H	L	L	L	H	21.67
H	L	L	H	L	21.77
H	L	L	H	H	22.05
H	L	H	L	L	22.57
H	L	H	L	H	22.84
H	L	H	H	L	22.95
H	L	H	H	H	23.40
H	H	L	L	L	23.59
H	H	L	L	H	24.02
H	H	L	H	L	24.25
H	H	L	H	H	24.43
H	H	H	L	L	25.29
H	H	H	L	H	25.43
H	H	H	H	L	25.90
H	H	H	H	H	26.02

AM3066 – Filter Bank

Digitally Tunable 12 to 26.5 GHz Bandpass



State Tables (continued)

18 -26.5 GHz Low Pass Control Lines				Typical Cutoff Frequency (GHz)
B_4	B_3	B_2	B_1	
L	L	L	L	16.51
L	L	L	H	18.52
L	L	H	L	18.93
L	L	H	H	19.24
L	H	L	L	19.37
L	H	L	H	20.00
L	H	H	L	20.40
L	H	H	H	21.07
H	L	L	L	21.77
H	L	L	H	22.80
H	L	H	L	23.82
H	L	H	H	24.91
H	H	L	L	25.54
H	H	L	H	28.06
H	H	H	L	29.33
H	H	H	H	31.30

AM3066 – Filter Bank

Digitally Tunable 12 to 26.5 GHz Bandpass

Typical Performance

*Note: Only some states shown for simplicity

12.0 – 18.0 GHz

Adjustable Bandwidth High 12to18 GHz

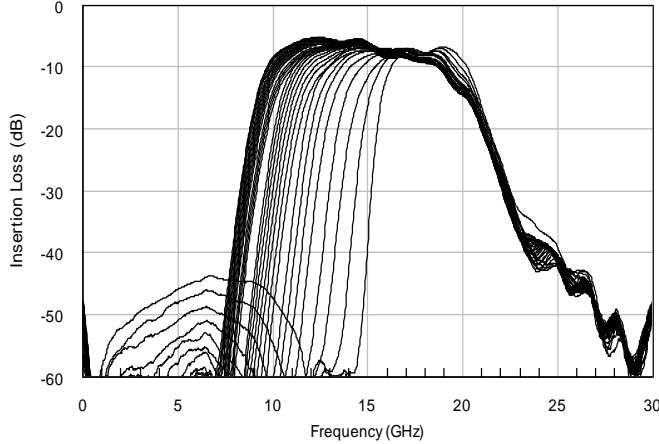

18.0 – 26.5 GHz

Adjustable Bandwidth High 18to26 GHz

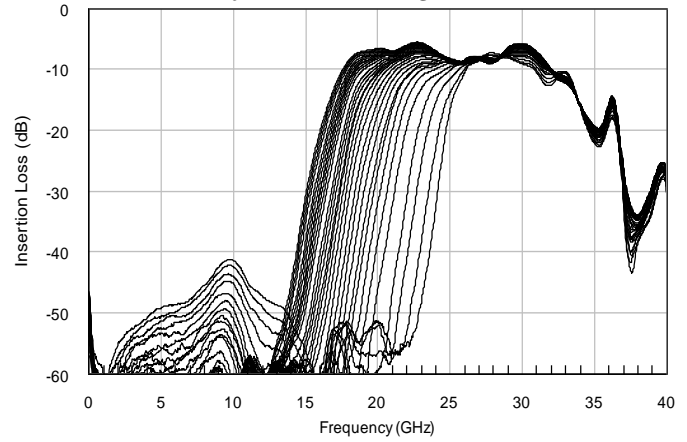

Adjustable Bandwidth Low 12to18 GHz

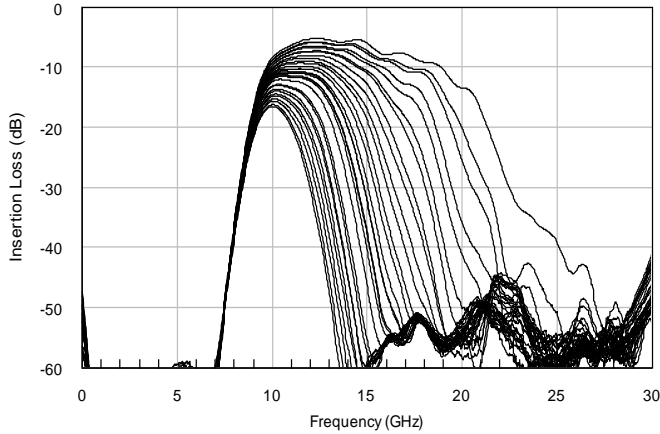

Adjustable Bandwidth Low 18to26 GHz

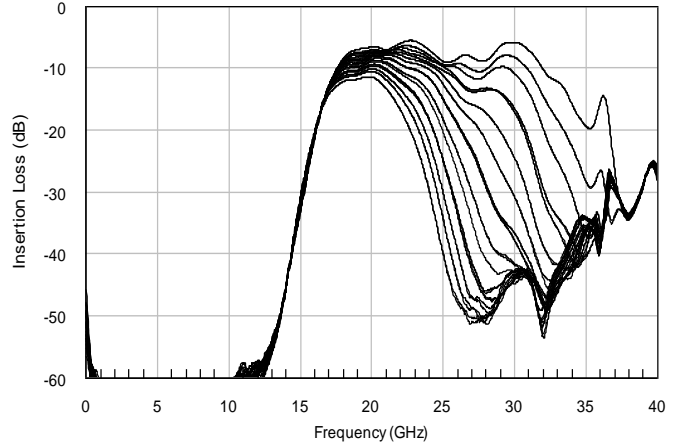

Return Loss 12to18 GHz

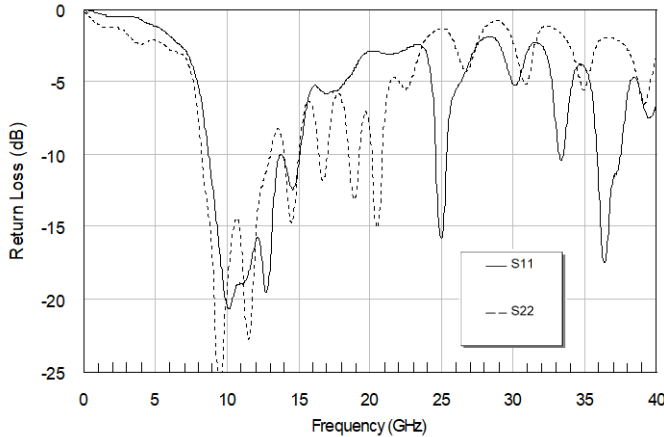

Return Loss 18to26 GHz

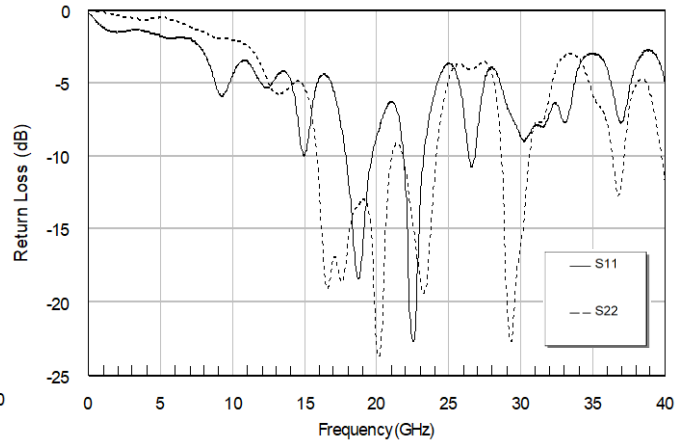

AM3066 – Filter Bank

Digitally Tunable 12 to 26.5 GHz Bandpass

Typical Performance (continued)

*Note: Only some states shown for simplicity

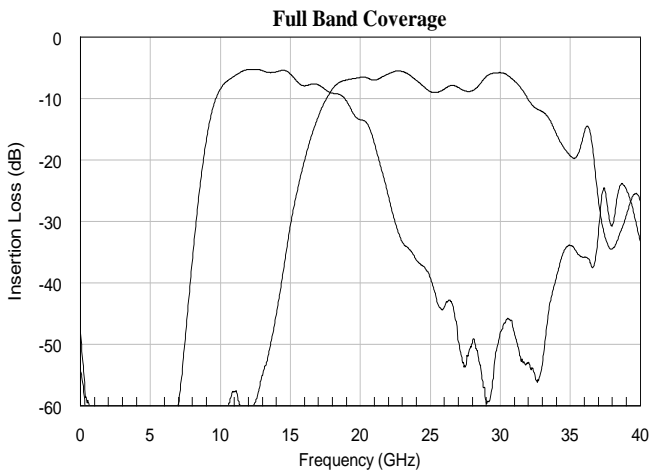
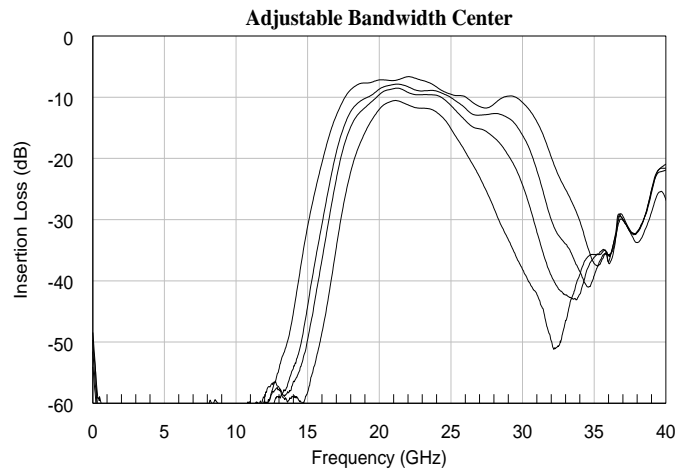
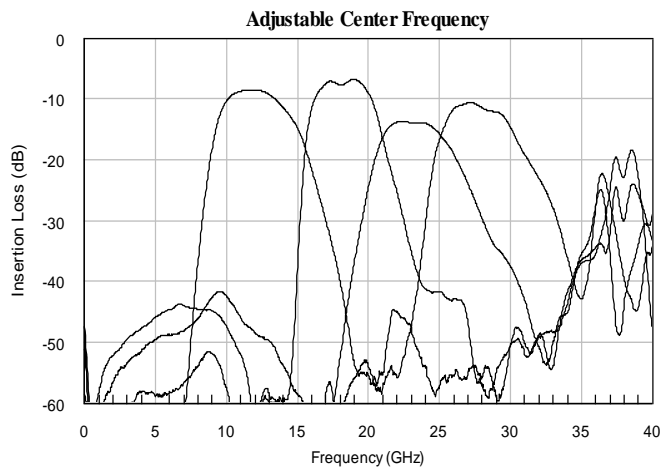

Typical Application

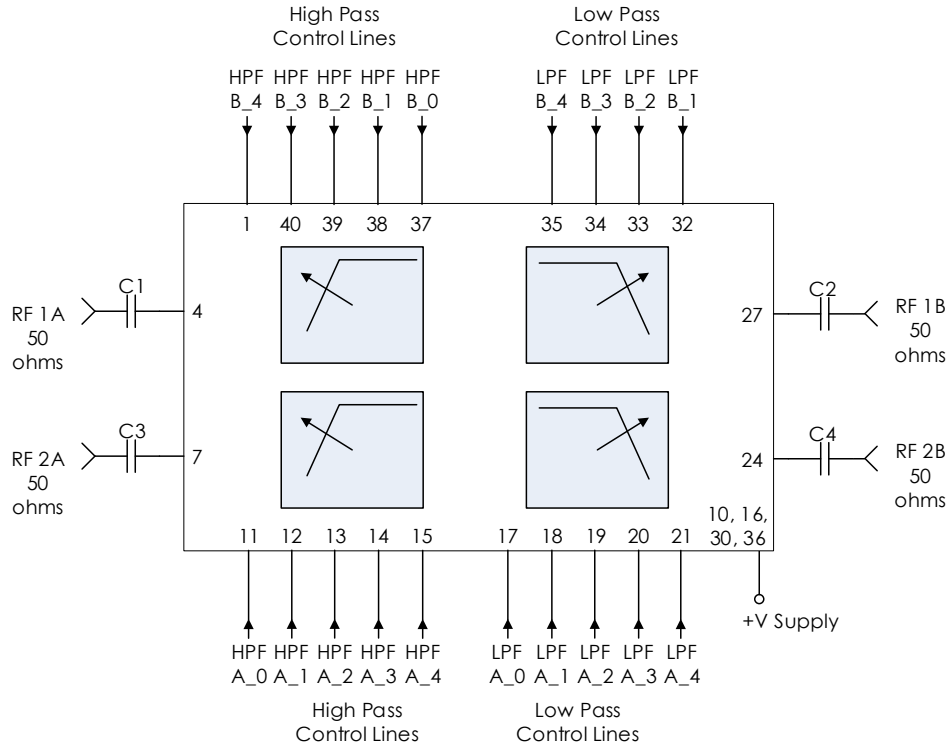

Recommended Component List (or equivalent):

Part	Value	Part Number	Manufacturer
C1 – C4	0.1 μ F	0201BB104KW160	Passive Plus

Notes:

- RF blocking capacitors should be high performance, low loss, broadband capacitors for optimum performance.
- VDD and control lines filtered internally providing high frequency isolation up to 50+ GHz.
 - No additional RC filtering required on control lines.
 - See AM35 datasheet for performance details

AM3066 – Filter Bank

Digitally Tunable 12 to 26.5 GHz Bandpass



Package Details

Package Drawing

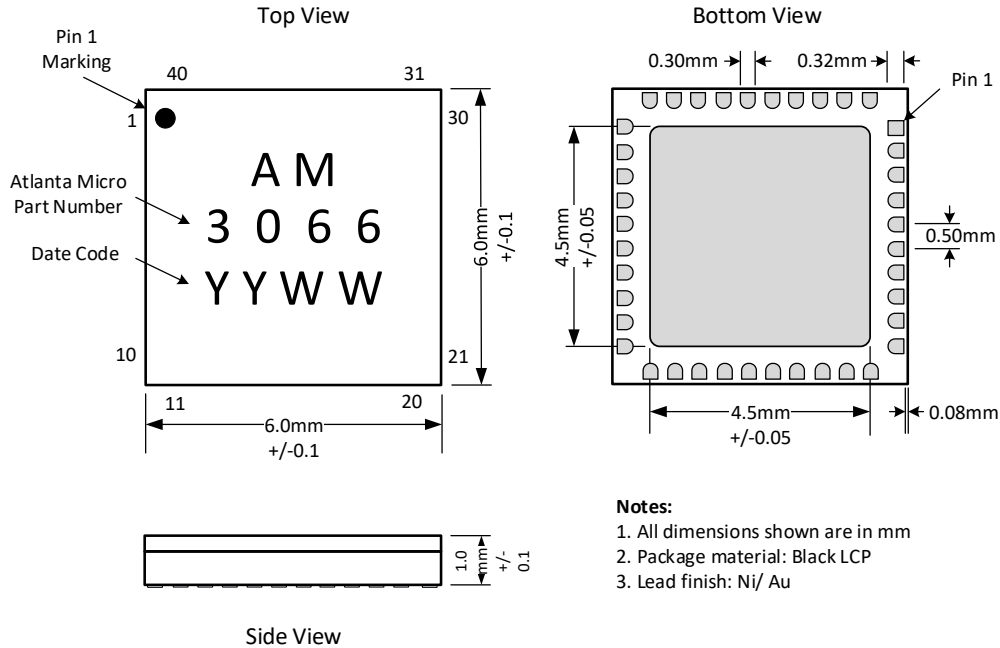

Recommended Footprint

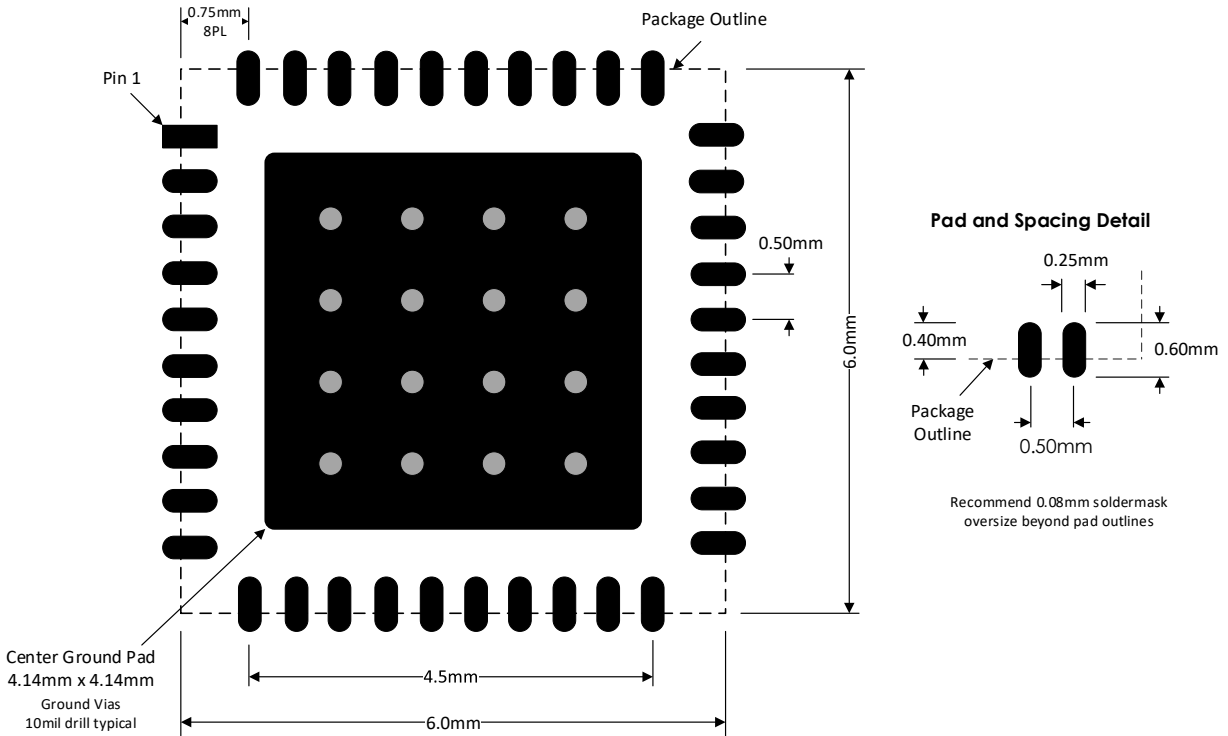

To obtain price, delivery, or to place an order contact sales@atlantamicro.com
 Atlanta Micro Inc., 3720 Davinci Ct, Suite 125, Norcross, GA 30092 • Phone: (470) 253-7640 • www.atlantamicro.com

AM3066 – Filter Bank

Digitally Tunable 12 to 26.5 GHz Bandpass

Evaluation PC Board

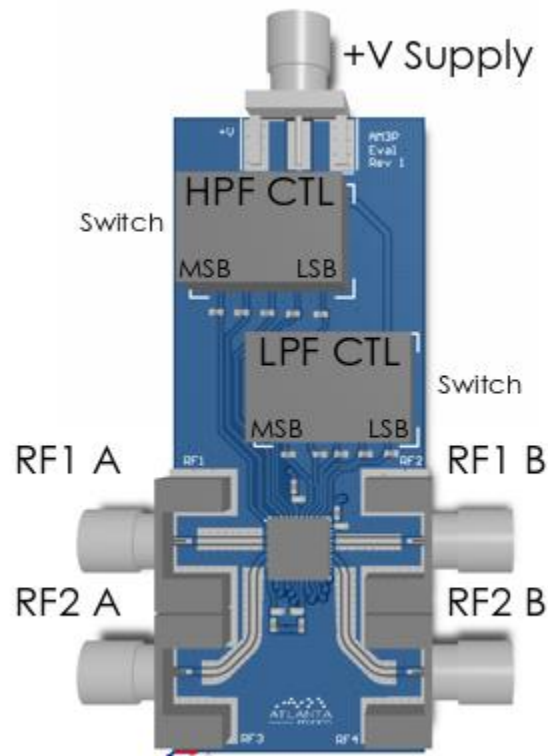

Related Parts

Part Number	Description		
AM3060	0.32 GHz	to 6.5 GHz	Switched Digitally Tunable BPF Bank
AM3063	6 GHz	to 18 GHz	Digitally Tunable Bandpass Filter Bank
AM3064	1 GHz	to 6.5 GHz	Digitally Tunable Bandpass Filter Bank
AM3065	6 GHz	to 12 GHz	Digitally Tunable Bandpass Filter
AM3089	2 GHz	to 18 GHz	Switched Analog Tunable BPF Bank
AM3134	2 GHz	to 4.5 GHz	Analog Tunable Bandpass Filter Bank
AM3135	3.5 GHz	to 9 GHz	Analog Tunable Bandpass Filter Bank
AM3136	8 GHz	to 19 GHz	Analog Tunable Bandpass Filter Bank
AM35	100 MHz	to 40 GHz	Power and Control EMI Filter Bank

Component Compliance Information

RoHS: Atlanta Micro, Inc. hereby certifies that all products comply with the EC Directive 2011/65/EC on the Restriction of Hazardous Substances, commonly known as EU-RoHS 6 and 10. All products supplied by Atlanta Micro shall be compliant with the European Directive 2011/65/EC based on the following substance list.

Substance List	Allowable Maximum Concentration
Lead (Pb)	<1000 PPM (0.1% by weight)
Mercury (Hg)	<1000 PPM (0.1% by weight)
Cadmium (Cd)	<75 PPM (0.0075% by weight)
Hexavalent Chromium (CrVI)	<1000 PPM (0.1% by weight)
Polybrominated Biphenyls (PBB)	<1000 PPM (0.1% by weight)
Polybrominated Diphenyl ethers (PBDE)	<1000 PPM (0.1% by weight)
Decabromodiphenyl Deca BDE	<1000 PPM (0.1% by weight)
Bis (2-ethylhexyl) Phthalate (DEHP)	<1000 PPM (0.1% by weight)
Butyl Benzyl Phthalate (BBP)	<1000 PPM (0.1% by weight)
Dibutyl Phthalate (DBP)	<1000 PPM (0.1% by weight)
Diisobutyl Phthalate (DIBP)	<1000 PPM (0.1% by weight)

REACH: Atlanta Micro, Inc. neither uses nor intentionally adds any of the substances considered to be a Substance of Very High Concern (SVHC) as defined by the EU Regulation (EC) No. 1907-2006 on Registration, Evaluation, Authorization, and Restriction of Chemicals (REACH).

Conflict Materials: Atlanta Micro does not knowingly use materials that are sourced from the Democratic Republic of Congo (DRC) or any other known conflict regions. Atlanta Micro's supply chain is comprised of sources that are both environmentally and socially responsible. We periodically review this requirement with our vendors to ensure continued compliance.

Atlanta Micro takes its responsibility as a global partner seriously and will use due diligence within our supply chain to ensure all standards are met to the best of our knowledge.